

### Plastic-Encapsulate MOSFETS

Dual P-Channel Power MOSFET

$V_{(BR)DSS}$	$R_{DS(on)MAX}$	$I_D$
-20V	520mΩ@-4.5V	-0.66A
	700mΩ@-2.5V	
	950mΩ(TYP)@-1.8V	

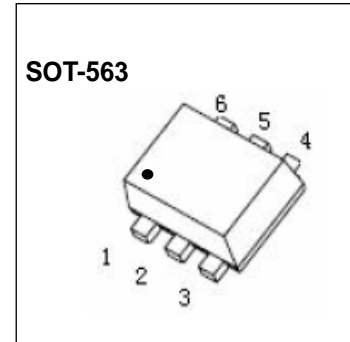

#### GENERAL DESCRIPTION

This Dual P-Channel MOSFET has been designed using advanced Power Trench process to optimize the  $R_{DS(ON)}$ .

Including two P-ch BC3139K MOSFET (independently) in a package.

#### FEATURE

- High-Side Switching
- Low On-Resistance
- Low Threshold
- Fast Switching Speed

#### APPLICATION

- Drivers: Relays, Solenoids, Lamps, Hammers, Displays, Memories
- Battery Operated Systems
- Power Supply Converter Circuits
- Load/Power Switching Cell Phones, Pagets

#### MARKING

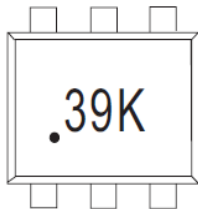

#### Equivalent Circuit

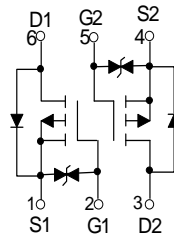

Maximum ratings ( $T_a=25^{\circ}C$  unless otherwise noted)

Parameter	Symbol	Value	Unit
Drain-Source voltage	$V_{DSS}$	-20	V
Typical Gate-Source Voltage	$V_{GS}$	±12	
Drain Current-Continuous	$I_{D(DC)}$	-0.66	A
Drain Current -Pulsed(note1)	$I_{DM(pulse)}$	-2.64	
Power Dissipation (note 2)	$P_D$	150	mW
Thermal Resistance from Junction to Ambient	$R_{\theta JA}$	833	$^{\circ}C/W$
Storage Temperature	$T_j$	150	$^{\circ}C$
Junction Temperature	$T_{stg}$	-55 ~+150	

### MOSFET ELECTRICAL CHARACTERISTICS

$T_a=25^\circ\text{C}$  unless otherwise specified

Parameter	Symbol	Test Condition	Min	Typ	Max	Unit
<b>On/Off States</b>						
Drain-Source Breakdown Voltage	$V_{(BR)DSS}$	$V_{GS} = 0V, I_D = -250\mu A$	-20			V
Gate-Threshold Voltage(note 3)	$V_{GS(th)}$	$V_{DS} = V_{GS}, I_D = -250\mu A$	-0.35		-1.1	V
Gate-Body Leakage Current	$I_{GSS}$	$V_{DS} = 0V, V_{GS} = \pm 10V$			$\pm 20$	$\mu A$
Zero Gate Voltage Drain Current	$I_{DSS}$	$V_{DS} = -20V, V_{GS} = 0V$			-1	$\mu A$
Drain-Source On-State Resistance(note 3)	$R_{DS(on)}$	$V_{GS} = -4.5V, I_D = -1A$		450	520	m $\Omega$
		$V_{GS} = -2.5V, I_D = -800mA$		575	700	
		$V_{GS} = -1.8V, I_D = -500mA$		950		
Forward Transconductance	$g_{FS}$	$V_{DS} = -10V, I_D = -540mA$	0.8			S
<b>Dynamic Characteristics(note 4)</b>						
Input Capacitance	$C_{iss}$	$V_{DS} = -16V, V_{GS} = 0V, f = 1MHz$			170	pF
Output Capacitance	$C_{oss}$				25	
Reverse Transfer Capacitance	$C_{rss}$				15	
<b>Switching Times (note 4)</b>						
Turn-On Delay Time	$t_{d(on)}$	$V_{DD} = -10V,$ $I_D = -200mA,$ $V_{GS} = -4.5V, R_G = 10\Omega$		9		ns
Rise Time	$t_r$			5.8		
Turn-Off Delay Time	$t_{d(off)}$			32.7		
Fall Time	$t_f$			20.3		
<b>Drain-Source Diode Characteristics</b>						
Drain-Source Diode Forward Voltage (note 3)	$V_{SD}$	$I_S = -0.5A, V_{GS} = 0V$			-1.2	V

**Notes:**

1. Repetitive Rating: Pulse width limited by maximum junction temperature.
2. This test is performed with no heat sink at  $T_a=25^\circ\text{C}$ .
3. Pulse Test : Pulse Width $\leq 300\mu s$ , Duty Cycle $\leq 0.5\%$ .
4. These parameters have no way to verify.

### Typical Characteristics

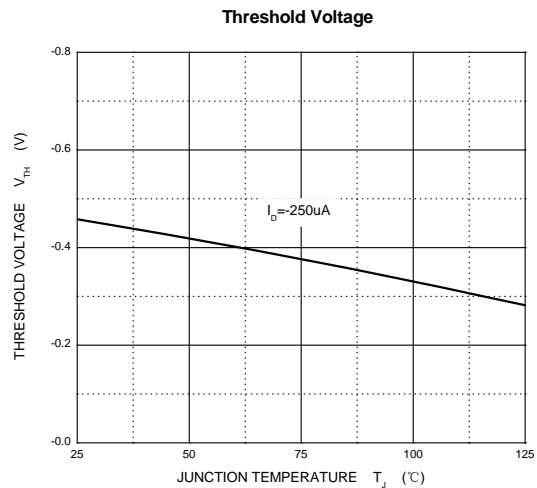
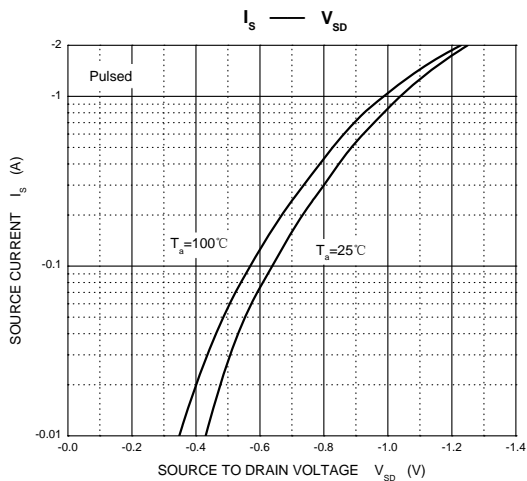
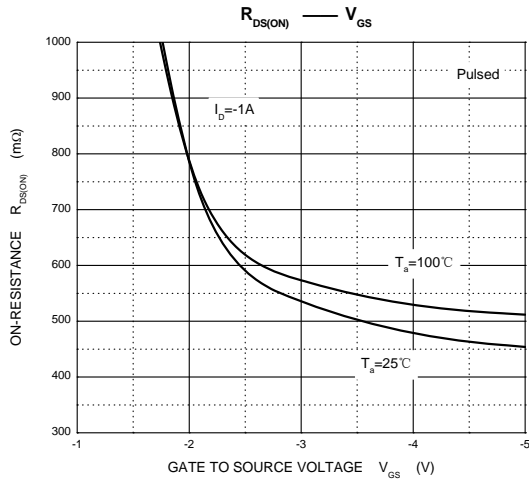
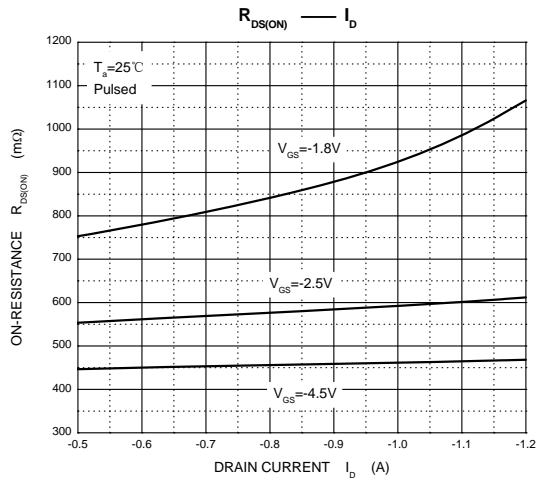
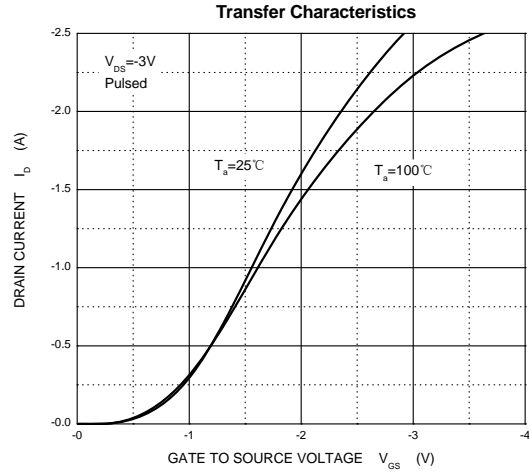
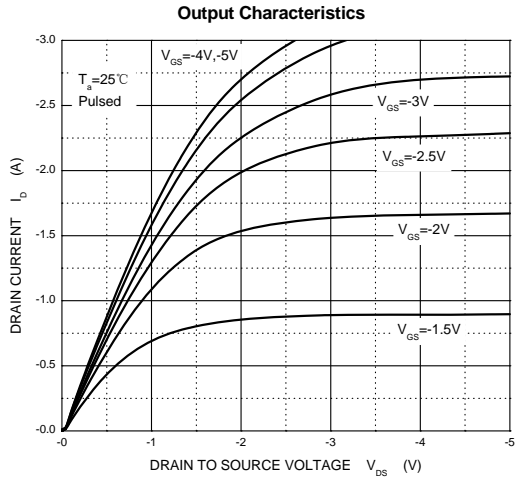

### SOT-563-Package Outline Dimensions

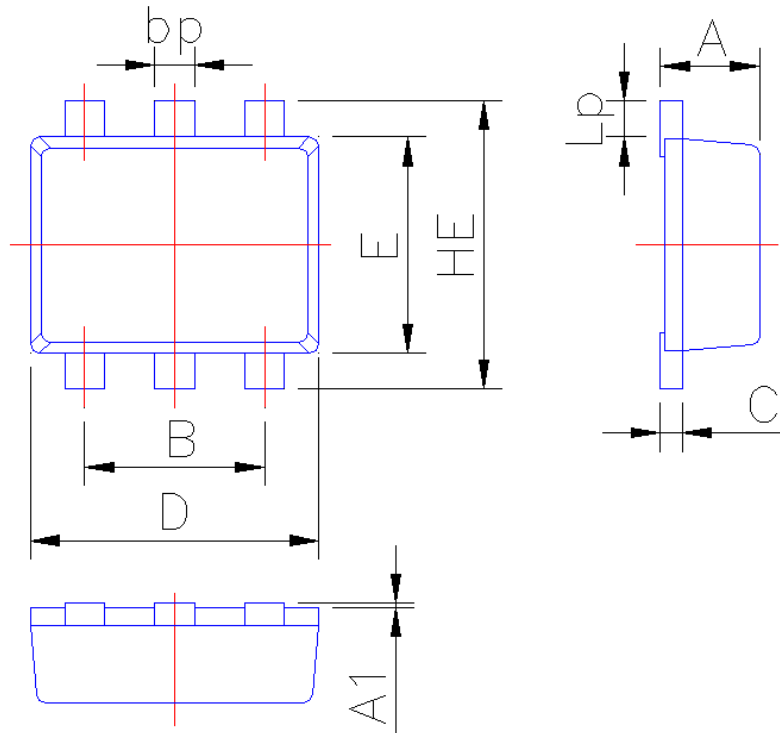

Symbol	Dimension in Millimeters	
	Min	Max
A	0.50	0.60
A1	0	0.05
B	0.95	1.05
bp	0.13	0.30
C	0.09	0.150
D	1.50	1.70
E	1.15	1.35
HE	1.40	1.80
Lp	0.13	0.30